



BYPASS, FILTER & BROMINE FEEDERS

OPERATION & MAINTENANCE MANUAL



PLEASE RECORD THE FOLLOWING DATA

(Information is located on the product label or packing slip)

Model Number: _____

Service: _____

Code: _____

Installation Date: _____

Installation Location / Application: _____

The above information will help when ordering replacement parts and accessories for your Wingert Bypass Feeder.

J.L. WINGERT CO. MANUFACTURED PRODUCTS

Mixers, Bypass Feeders, Filter Feeders, Bromine Feeders, Sample Coolers, Sludge Traps, Separators, Separator Systems, Tank Stands, Tank Package Systems, Glycol Feed Systems, Coupon Racks, Control Stations, NEMA Enclosures, Custom Packaged Systems and Specialty Welding

CONTENTS:**PAGE**

1.0	INTRODUCTION	2
2.0	WARRANTY	2
3.0	UNPACKING	2
4.0	MODEL NUMBER VERIFICATION	3-4
5.0	LOCATION AND ENVIRONMENT	4
6.0	SAFETY	5
6.1	SAFETY HIGHLIGHTS	5
7.0	INSTALLATION	5
7.1	INSTALLATION DIAGRAM—BYPASS FEEDERS, PLEATED FILTER FEEDERS, HIGH PRESSURE FEEDERS, BROMINE FEEDERS & ASME	6
7.2	INSTALLATION DIAGRAM—FILTER (BAG) FEEDERS	6
8.0	APPLICATION INFORMATION & TROUBLESHOOTING	7
9.0	PVC VALVE PACKAGES	7-8
10.0	VALVE PACKAGE INSTRUCTIONS	9
10.1	UNPACKING	9
10.2	INSTALLATION	9
11.0	FILTER BAG INSTRUCTIONS	9-10
11.0	INSTALLATION	10
12.0	ACCESSORY ITEMS	11
13.0	MAINTENANCE	11
14.0	PARTS LISTING	12

1.0 INTRODUCTION

J.L. Wingert Co. Feeders are designed to provide you with a rugged and reliable means of introducing chemicals into hot, chilled water or other liquids. Simplicity of design and ease of operation are inherent in every Wingert Feeder. The dual purpose Wingert Filter Feeder eliminates the need to install a separate bypass feeder and filter system saving time and money. Rugged reliability is engineered into our complete line of bypass, filter and bromine feeders which feature ease of installation and provide precise filtering capabilities down to 5 microns.

2.0 WARRANTY

Wingert Bypass, Filter & Bromine Feeders are warranted against manufacturing defects in material and workmanship for one year from the date of shipment. Applications outside the service for which the product is designed, including any non-factory modifications, will automatically void any warranty. Items returned to J.L. Wingert Co. for warranty consideration must be transported via prepaid freight. Final warranty determination will be made upon inspection. J.L. Wingert Co. will, at their discretion, repair or replace any defective item. Any repair or replacement outside warranted limitations will be considered a repair order and quoted accordingly. All replacements will be F.O.B. factory. There are no other implied or expressed warranties.

3.0 UNPACKING

Wingert Feeders are fully assembled and ready for installation. A feeder may be packed in a carton or shipped secured to a shipping pallet. Inspect packaging upon receipt for any damage. Unpack and inspect the product for damage and verify that goods received correlate with the packing list and product table on pages 3 and 4. Verify that no packing material has obstructed the inlet, outlet or purge openings. Notify the factory of any discrepancies immediately upon receipt. If any product is damaged due to freight handling, contact the factory immediately for further assistance. It is recommended that photo documentation of any damage or discrepancy be supplied to support any claims.

NOTE: Most freight carriers allow only a limited time after receipt of goods to file a freight claim.

4.0 MODEL NUMBER VERIFICATION

MODEL NUMBERING EXAMPLE

FILTER TYPE-	STYLE-	CAPACITY	FILL CLOSURE	/ OPTIONS
		5	HD	/AR
	DB-	2	HD	/SL300
F-	DB-	2	HD	/EK5
FHC-	DB-	12	HD	/EK6
PF-		5	HD	/ARPG



BYPASS FEEDERS AND FILTER FEEDERS Rated for 200 PSI @ 200°F

FILTER TYPE	
	Non-filter feeder
F	Filter - Bag 2, 5 and 12 gallon only
FHC	Filter High Capacity - Bag 2, 5 and 12 gallon only
PF	Pleated filter - 2, 5 and 12 gallon only

STYLE	
	Flat Bottom (no drain, no legs) - Standard Model Designation
DB	Dome Bottom (drain port and legs)

CAPACITY	
2	2 gallon capacity
5	5 gallon capacity
12	12 gallon capacity
18	18 gallon capacity

FILL CLOSURE	
HD	Heavy duty 3 1/2", 1/4 turn fill port

OPTIONS	
EK1	Epoxy coating inside only, 2 and 5 gallon sizes
EK2	Epoxy coating inside and outside, 2 and 5 gallon sizes
EK3	Epoxy coating outside only, 2 and 5 gallon sizes
EK4	Epoxy coating inside only, 12 and 18 gallon sizes
EK5	Epoxy coating inside and outside, 12 and 18 gallon sizes
EK6	Epoxy coating outside only, 12 and 18 gallon sizes
AR	Air release, 1/4" valve assembly in top dome
ARPG	Air release / pressure gauge, 1/4" valve and 300PSI gauge assembly in top dome
PG	Pressure gauge, 300PSI gauge assembly in top dome
FBK	Filter bag kit (converts 2, 5, and 12 gallon Bypass Feeders into a Filter Feeder, non-filter feeder only)
SL125	125 PSI / 200° F (2 & 5 gallon models)
SL125B	125 PSI / 200° F (12 gallon models)
SL125C	125 PSI / 200° F (18 gallon models)
SL300	300 PSI / 200° F (2 & 5 gallon models)
SL300B	300 PSI / 200° F (12 gallon models)
SL300C	300 PSI / 200° F (18 gallon models)

4.0 MODEL NUMBER VERIFICATION (CONTINUED)

HIGH PRESSURE BYPASS FEEDERS
 Rated for 300 PSI @ 200° F

MODEL NUMBERING EXAMPLE

STYLE-	CAPACITY-	MOUNT	/OPTIONS
HP-	5-	LEG	/AR



STYLE	
HP	High pressure (1" FNPT fill)

CAPACITY	
1	1 gallon capacity (without legs)
2	2 gallon capacity (with legs)
5	5 gallon capacity (with legs)
12	12 gallon capacity (with legs)

OPTIONS	
EK3	Epoxy coating outside only, 2 and 5 gallon sizes
EK6	Epoxy coating outside only, 12 and 18 gallon sizes
AR	Air release, 1/4" valve assembly in top dome
ARPG	Air release / pressure gauge, 1/4" valve 300 PSI gauge assembly in top dome
PG	Pressure gauge, 300 PSI gauge assembly in top dome
SL300	300 PSI / 200°F (2 & 5 gallon models)
SL300A	300 PSI / 200°F (1 gallon models)
SL300B	300 PSI / 200°F (12 gallon models)
ASME	Section VIII ASME Certified

MODEL NUMBERING EXAMPLE

MATERIAL-	STYLE-	CAPACITY	/OPTION
FRP-	DB-	2	/ARPVC



BROMINE (FIBERGLASS) BYPASS FEEDERS
 Rated for 150 PSI @ 150° F

MATERIAL	
FRP	Glass filled polyester resin (fiberglass)

STYLE	
	Flat Bottom (no drain port or stand) - Standard Model Designation
DB	Dome bottom (drain port and stand)

CAPACITY	
2	2 gallon capacity
5	5 gallon capacity
12	12 gallon capacity
16	16 gallon capacity

OPTION	
ARPVC	PVC air release valve and installation tee

5.0 LOCATION AND ENVIRONMENT

Wingert Feeders are designed for outdoor applications, however, exposure to extreme cold environment may freeze and expand contents causing vessel to burst. All feeders (except bromine) are coated with a water based enamel. Further protection may be added with one of the “-EK” epoxy coating options (except bromine feeders).

6.0 SAFETY

J.L. Wingert Co.'s equipment is designed and built with safety in mind. However, proper installation and operation can increase your overall safety.

DO NOT INSTALL, OPERATE OR REPAIR THIS EQUIPMENT WITHOUT READING THIS MANUAL AND THE SAFETY PRECAUTIONS CONTAINED THROUGHOUT. BE SURE THAT ALL INSTALLATION, OPERATION, MAINTENANCE AND REPAIR PROCEDURES ARE PERFORMED ONLY BY QUALIFIED INDIVIDUALS.

6.1 SAFETY HIGHLIGHTS

Read and understand the following safety highlights.

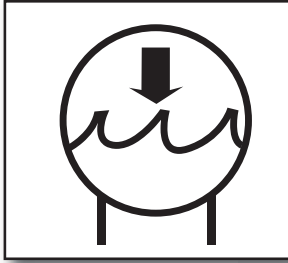

WATER PRESSURE INSIDE THE UNIT

See design specification for maximum operating pressure. Do not perform maintenance or repair without first releasing the water pressure and draining the fluid from the unit.



EQUIPMENT IDENTIFICATION LABEL

Identification label provides equipment information.

7.0 INSTALLATION

The following factors must be considered when installing your Wingert Feeder:

1. FLOWRATE

All Wingert Feeders are designed as bypass vessels and flow rate through feeder should not exceed:

- 1 GPM on 1 gallon feeders*
- 2 GPM on 2 gallon feeders*
- 5 GPM on 5 gallon feeders and larger*

2. PRESSURE DIFFERENTIAL

Pressure differential should not exceed 5 PSI on filtered feeders.

On all others, pressure differential should not exceed 10 PSI.

3. CREATING AND REGULATING FLOW AND PRESSURE DIFFERENTIAL

The key to any good installation is determining how you are going to create and control the flow rate and pressure differential. The most effective way to do this is to plumb the bypass line across the recirculation pump, or to install a throttling valve in the main line. Controlling the flow is most effective when using a flow control valve set at a factory preset flow rate. You may also use globe, gate or needle valves to achieve proper flow.

Use the following diagrams to decide which installation is the correct one for your application.

Consult your factory representative for variations in standard installations.

7.1 INSTALLATION DIAGRAM — BYPASS FEEDERS, PLEATED FILTER FEEDERS, HIGH PRESSURE FEEDERS, BROMINE FEEDERS & ASME
Bypass Feeders, Pleated Filter Feeders, High Pressure Feeders & Bromine Feeders use the lower side port for inlet and the upper side port for outlet.

See 7.2 for Bag Filter Feeder Installation

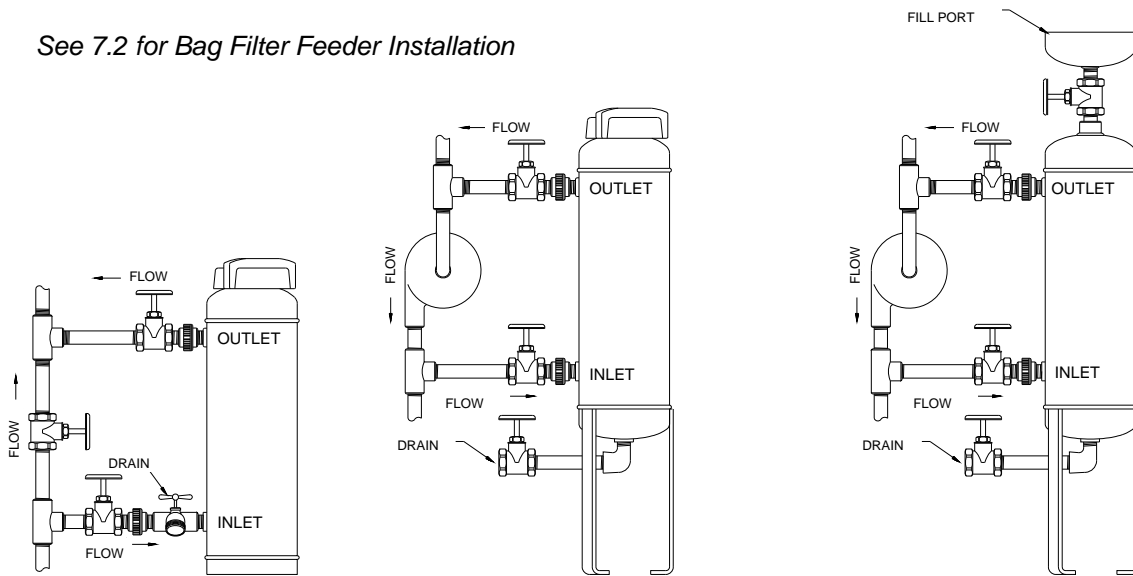

7.2 INSTALLATION DIAGRAM — FILTER (BAG) FEEDERS
Bag Filter Feeders use the upper side port for inlet and the lower side port for outlet.

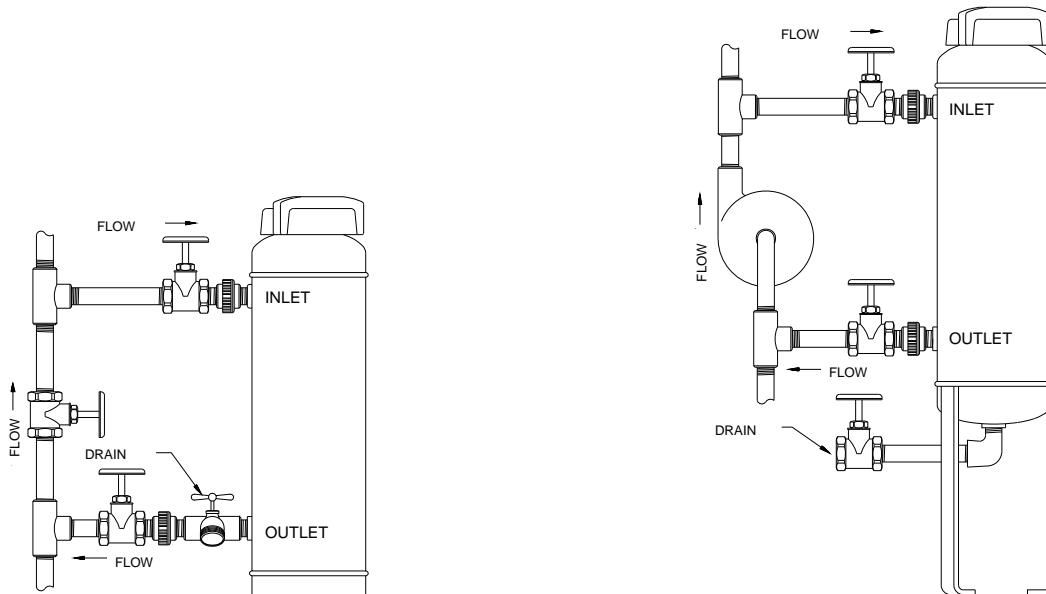

8.0 APPLICATION INFORMATION & TROUBLESHOOTING

Closely follow given guidelines. High temperature and excess pressure are often contributing factors in shortening feeder life. The largest contributing factor to decreasing the life of any feeder is trapped air. Once air is trapped in the feeder, the carbon steel will deteriorate rapidly. Removing excess trapped air is a necessity for any closed loop system.

TROUBLESHOOTING CHART

SYMPTOM	CAUSE	ACTION
Leaking at closure	Improper seating of o-ring	Remove cap, clean surface and reseal cap and closure. If problem persists, replace o-ring.
Leaking at fittings	Improper seal or cross threading of fittings	Remove fitting and sealant, then inspect threads for damage. If no damage is observed apply sealant (thread tape or pipe dope) and reseal fitting. If problem persists, replace fitting.
Filter damage	High particle content or excess flow rate	Check flow rate and control valves. Inspect filter chamber for solids content. Adjust valves and replace filter. Large particle content is often a typical problem during start up.
Interior corrosion	Trapped air or chemical content	Evidence of corrosion near the inside of vessel fill port is an indication of excessive trapped air. To remove trapped air, close isolation valves and fill feeder to the brim and reinstall closure. This should be done by trained personnel. If corrosion is covering body interior, check with chemical supplier for compatibility. Do not use feeder if there is excessive corrosion.
Leaking at seams	Unidentified pinhole during manufacture or excessive use	Occasionally, trapped gas during manufacturing may cause pin leaks to occur upon installation. Vessels that begin to leak after some time of service may be exhibiting normal wear. Typically there is no way to repair a vessel that exhibits wear; replacement may be necessary. Consult the factory for recommendation.

9.0 PVC VALVE PACKAGES

PVC Valve Packages are designed for use with Wingert Bromine Feeders. The chart below lists the available PVC Valve Package and the components of each valve package. For a schematic of each assembly see page 8.

PVC VALVE PACKAGES

MODEL	DESCRIPTION	INCLUDES KEY NUMBERS *
3200	Flat Bottom Bromine Feeder Valve Package	(1) #1, (1) #2
3201	Dome Bottom Bromine Feeder Valve Package	(2) #2, (1) #3
3202	PE Funnel with 1" Nipple and Valve	(1) #4

* See Page 8 for PVC Valve Packages key numbers.

9.0 PVC VALVE PACKAGES (CONTINUED)

PARTS, MATERIALS AND SPECIFICATIONS

KEY	DESCRIPTION	SPECIFICATIONS
1	Inlet and Drain Valve Assembly	3/4" PVC Sch. 80 valve, union and nipples, EPDM o-ring, Teflon ball valve seats
2	Inlet and Outlet Valve Assembly	3/4" PVC Sch. 80 valve, union and nipples, EPDM o-ring Teflon ball valve seats
3	Drain Valve Assembly	3/4" PVC Sch. 80 valve, elbow and nipples, 1" - 3/4" PVC Sch. 80 reducer, EPDM o-ring, Teflon ball valve seats
4	Option 3202	PE fill funnel with 1" PVC, Sch. 80 valve and nipples, Teflon ball valve seats
MAX. PRESSURE		150 PSI (10.4 BAR)
MAX. TEMPERATURE		120° F (66° C)

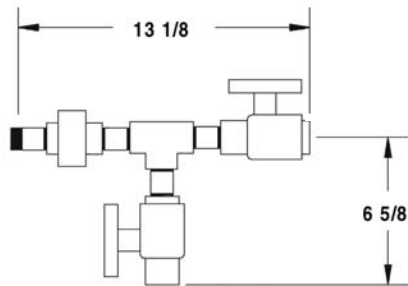

KEY 1

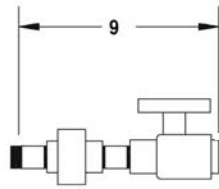

KEY 2

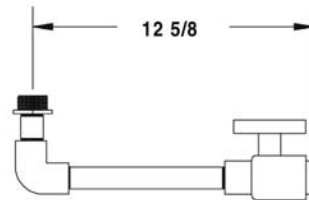

KEY 3

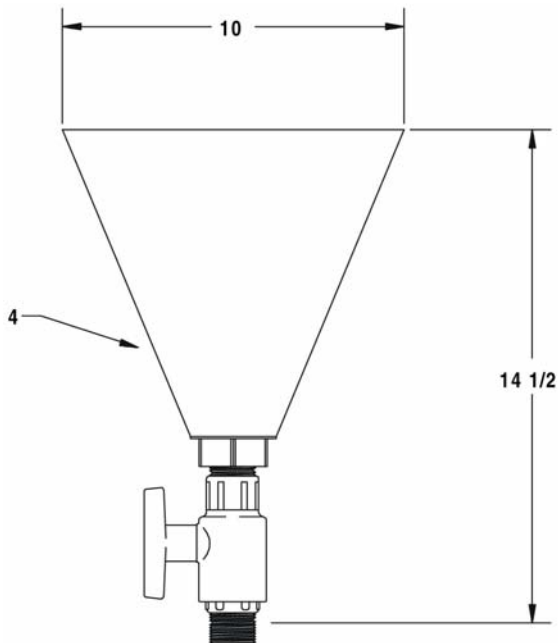

KEY 4

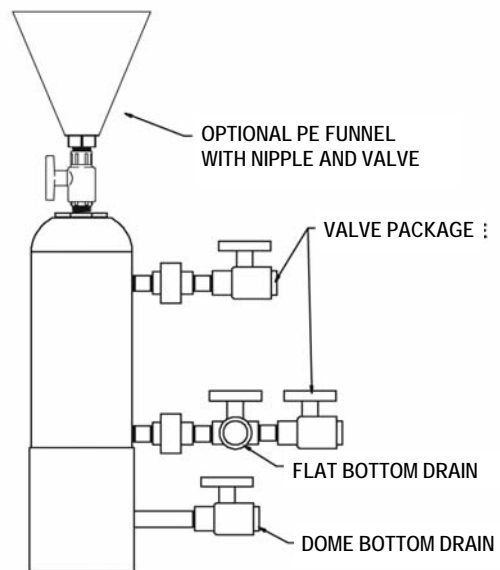

10.0 VALVE PACKAGE INSTRUCTIONS

10.1 UNPACKING

1) Ensure that there has been no damage in shipping. If any damage occurred, please notify the carrier and the J.L. Wingert Co. immediately.

10.2 INSTALLATION

1) Assemble valves and fittings as shown on the diagram below.
 2) Wingert Bypass Feeders and Pleated Filter Feeders should be installed with the inlet at the lower side entry. Wingert Filter Feeders should be installed with the inlet at the upper side fitting.

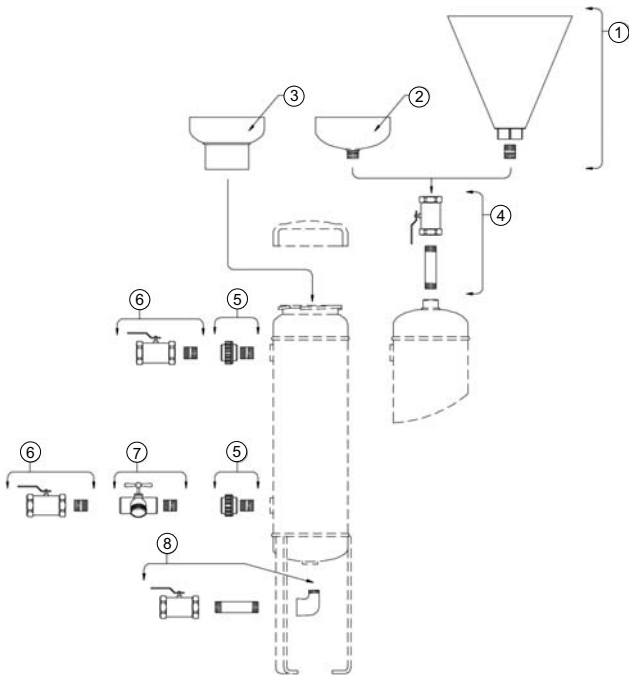

GENERAL NOTES

KEY	PART NUMBER	DESCRIPTION
1	3069P	PE FUNNEL: 10" diameter polyethylene fill funnel
2	3069	FUNNEL: 6" diameter carbon steel fill funnel
3	3218	FUNNEL: 6" diameter carbon steel fill funnel with spill guard
4	3142	FILL VALVE: 1" NPT 300PSI brass ball valve and installation nipple
5	3079	UNION: 3/4" NPT union and installation nipple
6	3141	ISOLATION VALVE: 3/4" NPT 300 PSI brass ball valve and installation nipple
7	3063	HOSE BIBB: 3/4" NPT 200 PSI with installation tee and nipple
8	3143	DRAIN VALVE: 3/4" NPT 300 PSI brass ball valve with installation street ell and nipple

VALVE PACKAGES

PART NUMBER	DESCRIPTION	INCLUDES KEY NUMBERS
3138	Flat bottom valve package	(2) #5 (2) #6 (1) #7
3138F	Flat bottom valve package with HD fill funnel	(1) #3 (2) #5 (2) #6 (1) #7
3139	Dome bottom valve package	(2) #5 (2) #6 (1) #8
3139F	Dome bottom valve package with HD fill funnel	(1) #3 (2) #5 (2) #6 (1) #8
3140	High pressure valve package with steel funnel	(1) #2 (1) #4 (2) #5 (2) #6 (1) #8
3140P	High pressure valve package with PE funnel	(1) #1 (1) #4 (2) #5 (2) #6 (1) #8

11.0 FILTER BAG INSTRUCTIONS

You can use your Wingert Bypass Feeder to remove solids from the water in recirculating systems by installing a Wingert Filter Bag Kit. While your feeder is not feeding chemical into the system, place a filter bag into the feeder and allow a continual flow of system water to bypass through the feeder. The filter bag will trap solids such as welding slag, rust chips, loose scale and precipitates in the system water. When the filter bag is full, remove it and replace it with a clean new filter bag.

11.0 FILTER BAG INSTRUCTIONS (CONTINUED)

Filter bag kits may be ordered when ordering a new Wingert Bypass Feeder, or they may be installed in a Wingert Bypass Feeder already in service. J.L. Wingert Co. also manufactures a line of filter feeders. When installing a filter bag kit into a feeder that is already in service, the connection piping will have to be modified slightly to accommodate the tank adapter unit.

Filter bags are fabricated from filament polyester cloth. Filter bags come standard with a 25 micron rating. Other micron ratings are available upon request. Suitable for temperatures up to 200° F, filter bags will withstand a pressure differential of 10 psi. The bag holder is fabricated from carbon steel wire and bar stock. The tank adapter uses brass dual ferrule fittings and 304 stainless steel tubing. The pipe connection is 3/4" FNPT.

Filter bag kits are available in three sizes depending on the size of your feeder:

Filter Bag Kit **3009**: Includes filter bag, bag holder, and tank adapter for 2 gallon feeder

Filter Bag Kit **3010**: Includes filter bag, bag holder, and tank adapter for 5 gallon feeder

Filter Bag Kit **3080**: Includes filter bag, bag holder, and tank adapter for 12 gallon feeder

Filter Bags **3070**: Box of 6 replacement bags, one size fits 2, 5 & 12 gallon feeders

11.1 INSTALLATION

- 1) If the Wingert Bypass Feeder is already installed, be certain that valves **(D)** and **(E)** are closed and drain valve **(F)** is open before starting installation. After flow stops at drain valve **(F)**, remove feeder from system piping.
- 2) Install tank adapter fitting **(B)** in feeder lower 3/4" FNPT fitting. Make certain that tube **(A)** is POINTING STRAIGHT UP before tightening tube nut **(B)**.
- 3) Connect system piping to tank adapter fitting **(C)**. If the feeder is already installed, the lower connection piping will have to be shortened.
- 4) Place filter bag over filter bag holder and tie closure draw string TIGHTLY.
- 5) Lower filter bag holder gently into feeder so that the tapered bag holder opening slips over tube **(A)**. When properly installed, the top of the filter bag will be slightly under the feeder lid and held in place when the lid is installed.
- 6) To replace filter bag, close valves **(D)** and **(E)** and open drain valve **(F)**. Remove feeder lid slowly to make certain that all pressure has been relieved through drain valve **(F)**.
- 7) When drain flow stops at valve **(F)**, remove filter bag and bag holder from the feeder. Replace dirt-filled bag with a fresh new bag, following instructions 4 and 5 above.

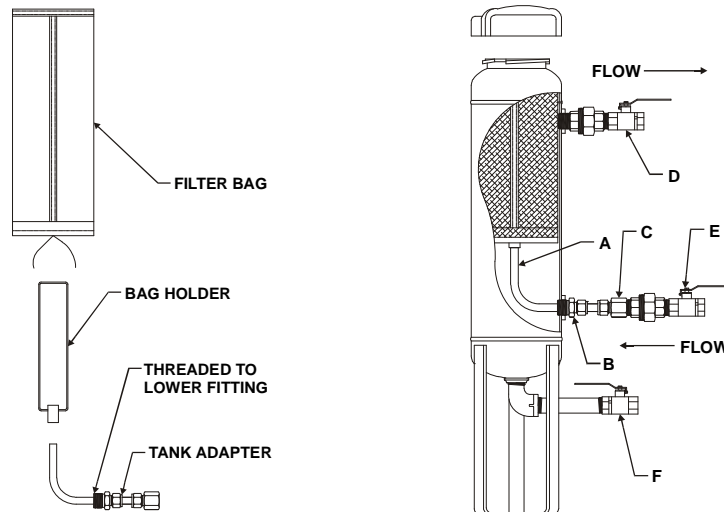

12.0 ACCESSORY ITEMS

Wingert Feeders are offered with a complete line of accessory items. The chart below lists their description and intended use.

BYPASS, FILTER & HIGH PRESSURE BYPASS FEEDERS ACCESSORIES CHART

PART	DESCRIPTION AND USE	DESIGNED FOR
3138 & 3138F	Valve package for flat bottom feeders. Includes inlet & outlet ball valves, unions, installation nipples, hose bib and tee. (Note: 3138F also includes carbon steel HD fill funnel with spill guard.)	Flat bottom feeders with 3 1/2" closure
3139 & 3139F	Valve package for dome bottom feeders. Includes inlet & outlet ball valves, unions, installation nipples and drain valve. (Note: 3139F also includes carbon steel HD fill funnel with spill guard.)	Dome bottom feeders with 3 1/2" closure
3140 & 3140P	Valve package for high pressure feeders. Includes inlet & outlet ball valves, unions, installation nipples, drain valve, 1" fill valve and fill funnel. (Note: 3140P includes PE fill funnel.)	High pressure feeders
3009, 3010 & 3080	Retrofit filter bag kit assembly for "HD" type feeders. Includes support tube, bag wire, bag and installation fittings. (Note: 3009 = 2 gallon, 3010 = 5 gallon & 3080 = 12 gallon).	"HD" style feeders
AR	Air release, 1/4" NPT valve assembly in top dome.	All feeders
PG	Pressure gauge, 0-300 PSI assembly in top dome.	All feeders
3061	3/4" MNPT in-line PVC Sch. 80 strainer with installation nipple.	All feeders
3086	3/4" NPT brass sight flow indicator (125 PSI, 100° F) with installation nipple.	All feeders (PSI/TEMP limited)
3069 & 3069P	1" NPT fill funnel (3069 is carbon steel & 3069P is polyethylene).	"HP" style feeders
3218	"HD" series carbon steel fill funnel with spill guard.	"HD" style feeders

BROMINE FIBERGLASS FEEDERS ACCESSORIES CHART

PART	DESCRIPTION AND USE	WORKS WITH
3200	Valve package for flat bottom fiberglass feeders. Includes inlet & outlet ball valves, unions, installation nipples, drain valve and tee.	Flat bottom fiberglass feeders
3201	Valve package for dome bottom fiberglass feeders. Includes inlet & outlet ball valves, unions, installation nipples and drain valve with elbow and installation nipple.	Dome bottom fiberglass feeders
3202	PE fill funnel and isolation valve.	All fiberglass feeders
3203 & 3204	Rechargeable PVC flow through dissolving chamber, 1" NPT fill port, 1/8" port (3203 = 2 gallon, 3204 = 5, 12 & 16 gallon models).	All fiberglass feeders
ARPVC	PVC air release valve, installation tee and nipple	All fiberglass feeders

13.0 MAINTENANCE

When filling or inspecting a feeder, ensure that the vessel is not under pressure. Close isolation valves and open drain valve before opening fill port. **Caution: Opening air release valve will release pressure along with the possibility of residual contents of vessel.**

Feeders generally need very little maintenance. Consult a water treatment specialist to schedule servicing or recharging of the system. It is most important to always purge trapped air when returning feeder to service. Filters should be maintained based on solids in system. Check frequently until schedule can be determined.

14.0 PARTS LISTING

CATEGORY	PART	DESCRIPTION
CLOSURE	3071	3 1/2" - 1/4 turn cast closure with pressure plate and standard o-ring
	3072	200°F standard o-ring
	3073	400°F optional o-ring
FILTER BAG KITS	3083	Bag support wire assembly for 2 & 5 gallon filter bag kits
	3101	Bag support wire assembly for 12 gallon filter bag kits
	3084	Filter bag kit support tube assembly for 2 gallon models
	3085	Filter bag kit support tube assembly for 5 & 12 gallon models
	3070	Filter bags, box of six filters for above filter bag kits, 25 micron
FILTER FEEDERS	3128	Perforated basket assembly for 2 & 5 gallon models
	3129	Perforated basket assembly for 12 gallon models
	3131	Replacement 25 micron filter bag with ring for 2 & 5 gallon models
	3132	Replacement 25 micron filter bag with ring for 12 gallon models
	3134	Box of six filter bags for 2 and 5 gallon filter feeder, 25 micron
	3135	Box of six filter bags for 12 gallon filter feeder, 25 micron
HIGH CAPACITY FILTER FEEDERS	3160	Perforated basket assembly for all models
	3161	Replacement 25 micron filter bag with ring for all models
	3162	Box of six filter bags for high capacity filter feeders, 25 micron
PLEATED FILTER FEEDERS	3186	Hanger assembly for all models
	3187	Pleated 20 micron filter for all models
	3189	Box of six pleated filters, 20 micron
VALVE PACKAGE	3141	3/4" NPT brass ball valve and installation nipple
	3142	1" NPT brass ball valve and installation nipple
	3079	3/4" NPT union with installation nipple
	3063	3/4" NPT 200PSI brass hose bib with installation nipple and tee
	3218	Funnel, "HD" series steel funnel with spill guard
	3069	Funnel, 1" NPT steel funnel
	3069P	Funnel, 1" NPT polyethylene funnel
FIBERGLASS FEEDERS	3205	2 1/2" CPVC closure with o-ring
	3206	4" CPVC closure with o-ring
	3061	Strainer, 3/4" MNPT in-line PVC Sch. 80 with installation nipple

Note: Other parts available upon request. Please contact customer service at customerservice@jlwingert.com for information and availability.

P.O. Box 6207 • Garden Grove, CA 92846-6207 / 11800 Monarch St. • Garden Grove, CA 92841-2113 • Phone (714) 379-5519 • Fax (714) 379-5549
Northern California Region • Phone (510) 487-5310 • Southwest Region • Phone (602) 470-1015 • Email: customerservice@jlwingert.com

www.jlwingert.com

