

# PULSAFEEDER®

The Chem-Tech PRIME PERFORMANCE Series pumps have a specially designed degassing valve system for applications using off-gassing chemicals like sodium hypochlorite. Built upon motorized-diaphragm technology, the PRIME PERFORMANCE Series delivers dependable performance, extended longevity and consistent metering over long periods of time in a compact form.

A top-mounted, one-way vent valve assembly evacuates gas bubbles from the pump head, providing for reliable operation. Simple, adjustable stroke system with locking lever provide easy flow rate control and turndown. The compact, injection-molded housing and PVC pump head offer both affordability and chemical resistance. The industrial grade, low-stress diaphragm provides long life, even in the harshest conditions or longest duty cycles.

**PP100 Models** - Perfect for off-gassing applications where economical, consistent performance is required. Capable of a wide range of flows, from less than 15 USGPD (2.34 lph) up to 30 USGPD (4.72 lph) and pressures up to 100 PSIG (7 BAR).

**PP150 Models** - Built upon the same solid platform as the 100 Models, these units are capable of higher flow rates. With a range offering up to 100 USGPD (15.76 lph), the Series 150 can meet the demands of larger applications. Maximum pressure is 60 PSIG (4.2 BAR).

## FEATURES

- Degassing Pump Head.
- Guided Quad Check Valve System.
- Bleed Valve Assembly Standard.

## CONTROLS



### Feed Rate Control

- Adjustable Feed Rate.

## OPERATING BENEFITS

- Reliable metering performance.
- Sealed gear train.
- Self priming.
- Chemical resistant materials.
- Simple installation.



Standard Agency Listings		
Model	ETL	ETL san
All 60Hz	X	X
All 50 Hz		
Contact factory for alternate listings		

 **CHEM-TECH**  
Prime Performance  
Mechanical Metering Pumps

# SPECIFICATION AND MODEL SELECTION

MODEL PP100	Control Parameters		MODEL PP150	Control Parameters
X015	15 gpd (2.34 lph) max pres.: 100 PSI (7 BAR)		X068	68 gpd (10.72 lph) max pres.: 60 PSI (4 BAR)
X024	24 gpd (3.78 lph) max pres.: 100 PSI (7 BAR)		X100	100 gpd (15.76 lph) max pres.: 60 PSI (4 BAR)
X030	30 gpd (4.72 lph) max pres.: 100 PSI (7 BAR)			

## ENGINEERING DATA

Pump Head Materials Available	PVC
Diaphragm	Viton, PTFE-faced CSPE backed
Check Valves Materials Available	
Seats/O-Rings	CSPE, Viton
Balls	Ceramic
Fittings Materials Available	PVC
Injection Valve & Foot Valve Assy	Same as fitting and check valve selected
Tubing	Clear PVC, White PE, Black PE

Viscosity Max CPS	20 CPS
Power Input	115 VAC/60 HZ, 230 VAC/50 HZ, 230 VAC/60 HZ
Temperatur Limitaions	125°F / 51°C max
Shipping Weight	8 lbs. / 3.63 kg.
Approvals	Conforms to ANSI/NSF STD. 50 Equipment for swimming pools, spas, hot tubs, and other recreational water facilities.

Important: Material Code - GFPL=Glass-filled Polypropylene, PVC=Polyvinyl Chloride, PE=Polyethylene, CSPE=Generic formulation of Hypalon, a registered trademark of E.I. DuPont Company. Viton is a registered trademark of E.I. DuPont Company. PVC wetted end recommended for sodium hypochlorite.

## AFTERMARKET

- KOPkits
- Gauges
- Dampeners
- Pressure Relief Valves
- Tanks
- Process Controllers (MicroVision)

## INTEGRATED TANK SYSTEMS



Pulsafeeder's ITS System is a completely integrated tank system constructed of high density UV resistant polyethylene (PE) with a 15 gallon capacity. This tank system is translucent with 5 gallon increments and the tank's low level indicator allows visual monitoring of chemicals without opening the tank. The tight fitting child proof lid keeps the chemical free of contaminants and protects the surrounding area from chemical fumes. The ITS System also allows for easy access to the liquid end and control panel of the mounted pump. A system consists of a chemical tank with lid and bulkhead fittings, a liquid level indicator float assembly and feeder mounting hardware.

## DIMENSIONS

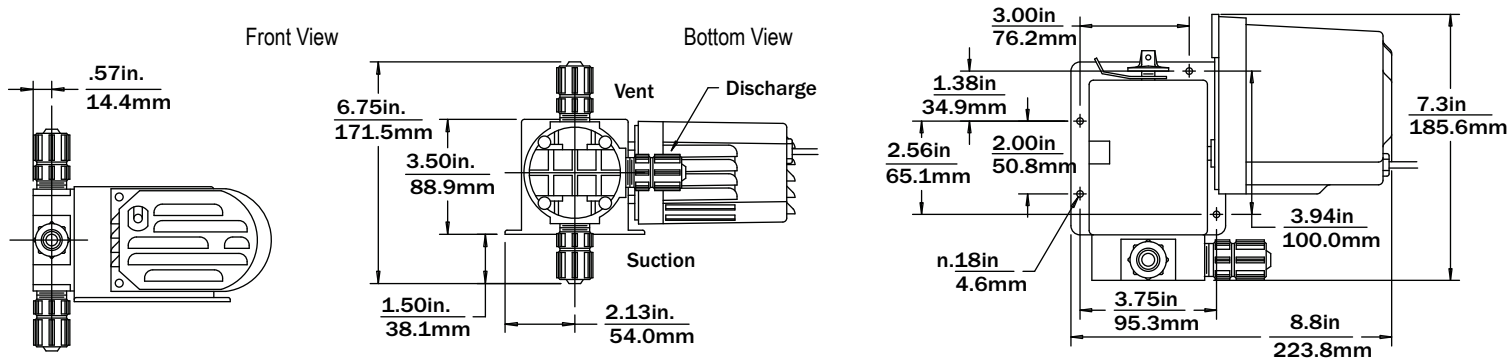

27101 Airport Road  
 Punta Gorda, FL 33982  
 Tel: (941) 575-3800  
 Fax: (941) 575-4085  
[www.pulsatron.com](http://www.pulsatron.com)



An ISO Certified Company

sales@watertreatmentsupply.com  
 Office: 954-772-2129  
[www.watertreatmentsupply.com](http://www.watertreatmentsupply.com)

**IBEX**  
 CTI0018 F21