

# J.L. WINGERT CO.

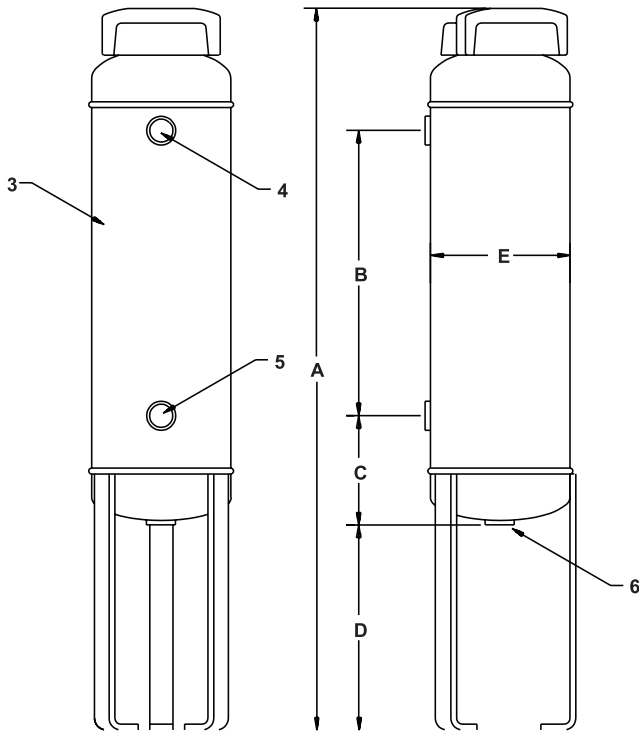

## Specification Sheet DOME BOTTOM BYPASS FEEDERS

SS030002.A 10/12

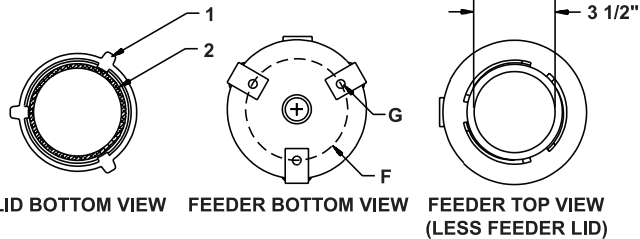

### PARTS, MATERIALS AND SPECIFICATIONS

KEY	PART	SPECIFICATIONS
1	3071	CLOSURE: 3 1/2" cast iron, 1/4 turn closure, (O-ring included)
2	3072	O-RING: Buna-N O-ring 200°F
3		BODY: Carbon steel
4		OUTLET: 3/4" FNPT
5		INLET: 3/4" FNPT
6		DRAIN: 3/4" FNPT
MAX. PRESSURE		200 PSI (13.6 BAR)
MAX. TEMPERATURE		200°F (93°C)

### VOLUME (FILL CAPACITY)

MODEL	GALLONS	LITERS
DB-2HD	2.39	9.04
DB-5HD	6.30	23.85
DB-12HD	13.28	50.27
DB-18HD	19.74	74.72

### DIMENSIONS, WEIGHT & CUBE:

KEY	DB-2HD	DB-5HD	DB-12HD	DB-18HD
A	30 3/4"	30 1/2"	51 1/4"	70 1/8"
B	12 1/2"	10 5/8"	31"	44"
C	4 3/8"	5 7/8"	5 7/8"	10 1/2"
D	8 3/4"	7 3/4"	7 3/4"	7 1/2"
E	6"	10"	10"	10"
F	4"	8"	8"	8"
G	3/8"	3/8"	3/8"	3/8"
WEIGHT	23 lbs. (10.4 kgs.)	37 lbs. (16.8 kgs.)	62 lbs. (28.1 kgs.)	86 lbs. (39 kgs.)
CUBE	6" x 6" x 32"	10" x 10" x 32"	10" x 10" x 53"	10" x 10" x 72"

Note: All dimensions are +/- 1/8". All weights are approximate. All dimensions are subject to change without notice.

MANUFACTURING: Mixers, Bypass Feeders, Filter Feeders, Bromine Feeders, Sample Coolers, Sludge Traps, Separators, Separator Systems, Tank Stands, Tank Package Systems, Glycol Feed Systems, Coupon Racks, Control Stations, NEMA Enclosures, Custom Packaged Systems and Specialty Welding

P.O. Box 6207 • Garden Grove, CA 92846-6207 / 11800 Monarch St. • Garden Grove, CA 92841-2113 • Phone (714) 379-5519 • Fax (714) 379-5549  
Northern California Region • Phone (510) 487-5310 • Southwest Region • Phone (602) 470-1015 • Email: customerservice@jllwingert.com

[www.jllwingert.com](http://www.jllwingert.com)