

DEGASSING HEAD ASSEMBLY

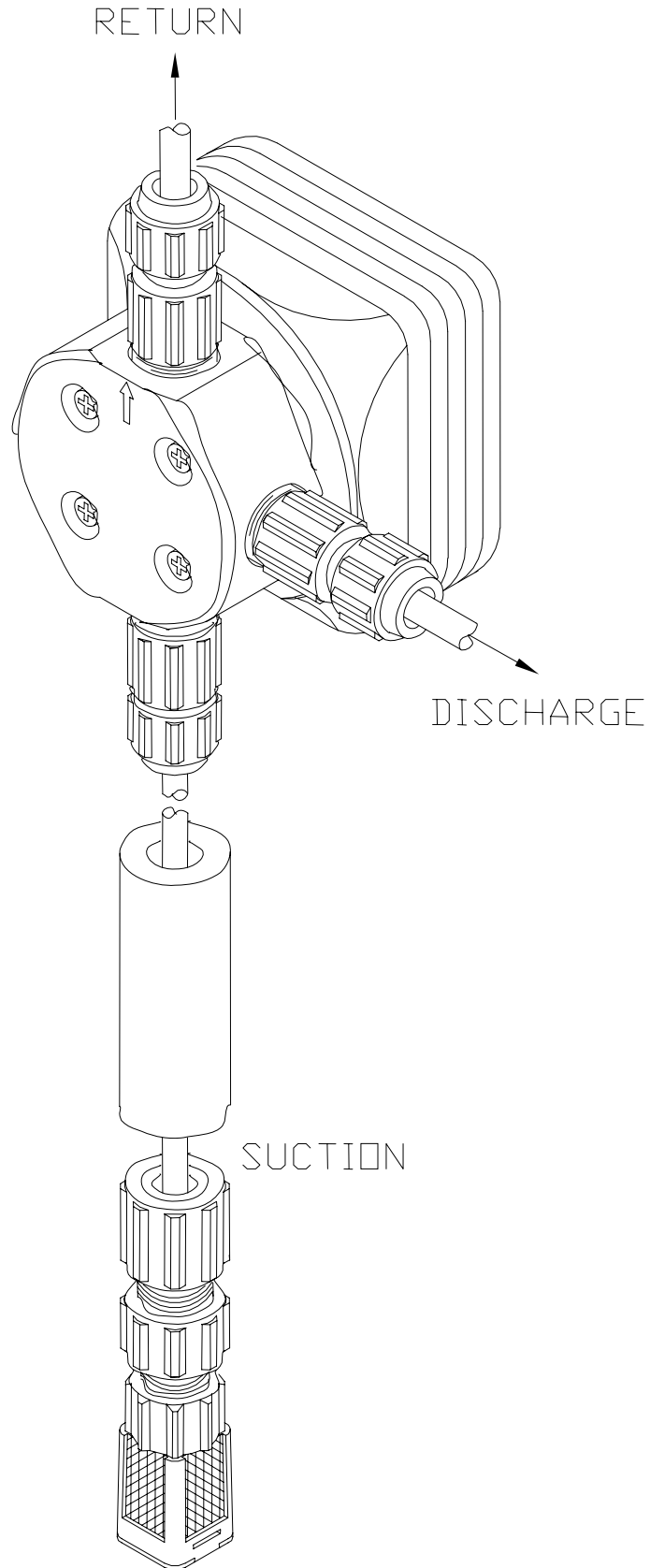

DEGASSING HEAD PUMP INSTALLATION INSTRUCTIONS

⚠CAUTION Before performing any maintenance or repairs on chemical metering pumps, be sure to disconnect all electrical connections and insure that all pressure valves are shut off and pressure in the pump and lines has been bled off.

Always wear protective clothing, gloves and safety glasses when performing any maintenance or repairs on chemical metering pumps.

FOR INSTALLING THE DESASSING HEAD: FOLLOW STEPS #6 thru #8.

OR

FOR CONVERTING FROM STANDARD HEAD TO A DEGASSING HEAD: FOLLOW STEPS #1 thru #8.

1. Disconnect the suction, discharge and return tubing (if applicable) from the pump head.
2. Remove the four head bolts from the pump head. Remove the head assembly from the pump.
3. Place the degassing pump head assembly on the pump with the arrows on the head and the suction and return valves pointing in the upward direction.
4. Reinstall the four head bolts. Tighten bolts evenly (crisscross pattern) to 18-22 inch pounds.
5. Cut approximately one inch off of the ends of the discharge and return tubing (if applicable). Cut the tubing squarely to ensure a good seal when reconnecting the tubing to the degassing head.
6. Using the clear .38" O.D. PVC suction tubing connect one end to the suction valve on the bottom of the pump head assembly.
 - a) For a flooded suction installation, connect the other end of the suction tubing to the tank bulkhead fitting
 - b) For non-flooded suction installation, slide the suction tubing through the strainer weight. Install the foot valve and strainer to the end of the tubing and place the suction line in the solution tank. For best performance, ensure that the suction line hangs vertically and is as short as possible with the strainer placed near the bottom of the solution tank. The strainer should be above any sediment which may form on the bottom of the solution tank.
7. Connect the discharge tubing to the discharge valve on the side of the pump head.
8. Connect the clear .38" O.D. PVC return tubing to the de-gas valve directly on the top of the pump head assembly. Secure the other end of the return tubing to the tank above the solution level. The return line must be maintained above the solution level in the tank for proper operation.

Note: When using a degassing head, a bleed valve is not required, and should not be installed.

PRIMING

1. Turn on power to the pump.
2. Adjust the stroke length knob to the 100% mark.
3. Adjust the stroke rate knob(if applicable) to the 100% mark.
4. At this point the pump will automatically purge the air from the pump head via the degass valve. Once the fluid starts pumping out the discharge line, readjust the pump flow to the desired rate.

Please note that the de-gas valve was designed to return a small amount of fluid back to the tank when the pump is operating. Fluid being returned via the return line to the tank is part of the proper operation of the degassing head. Pump output will be reduced, verify your output and adjust as necessary.

DEGASSING HEAD, FLOODED SUCTION INSTALLATION (NOT RECOMMENDED)

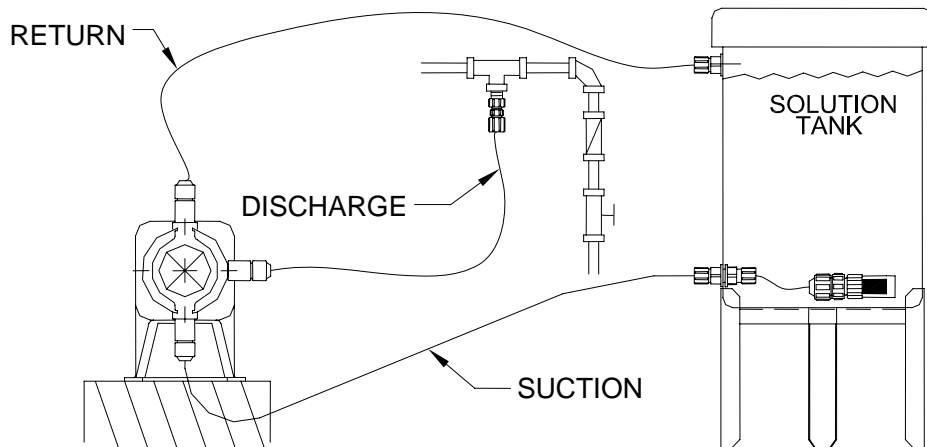

DEGASSING HEAD, NON-FLOODED INSTALLATION

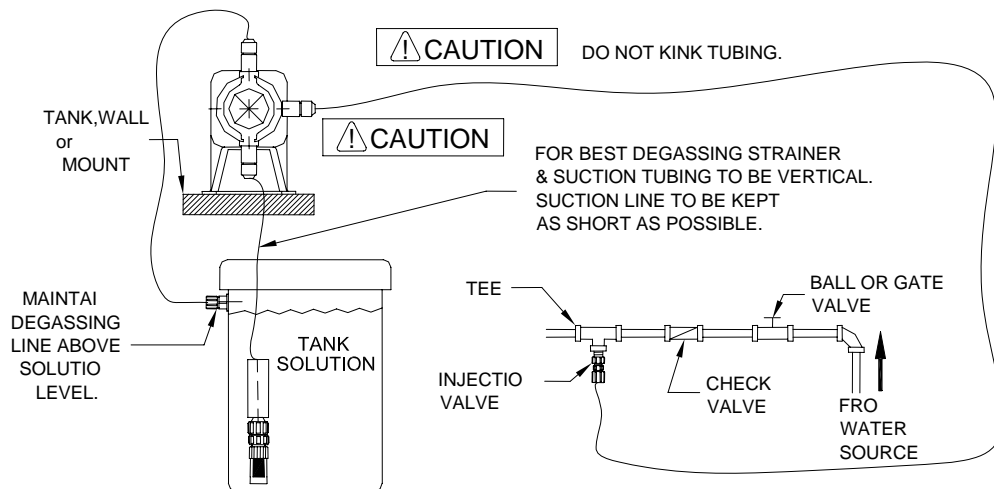

STANDARD DEGASSING HEAD CONNECTIONS

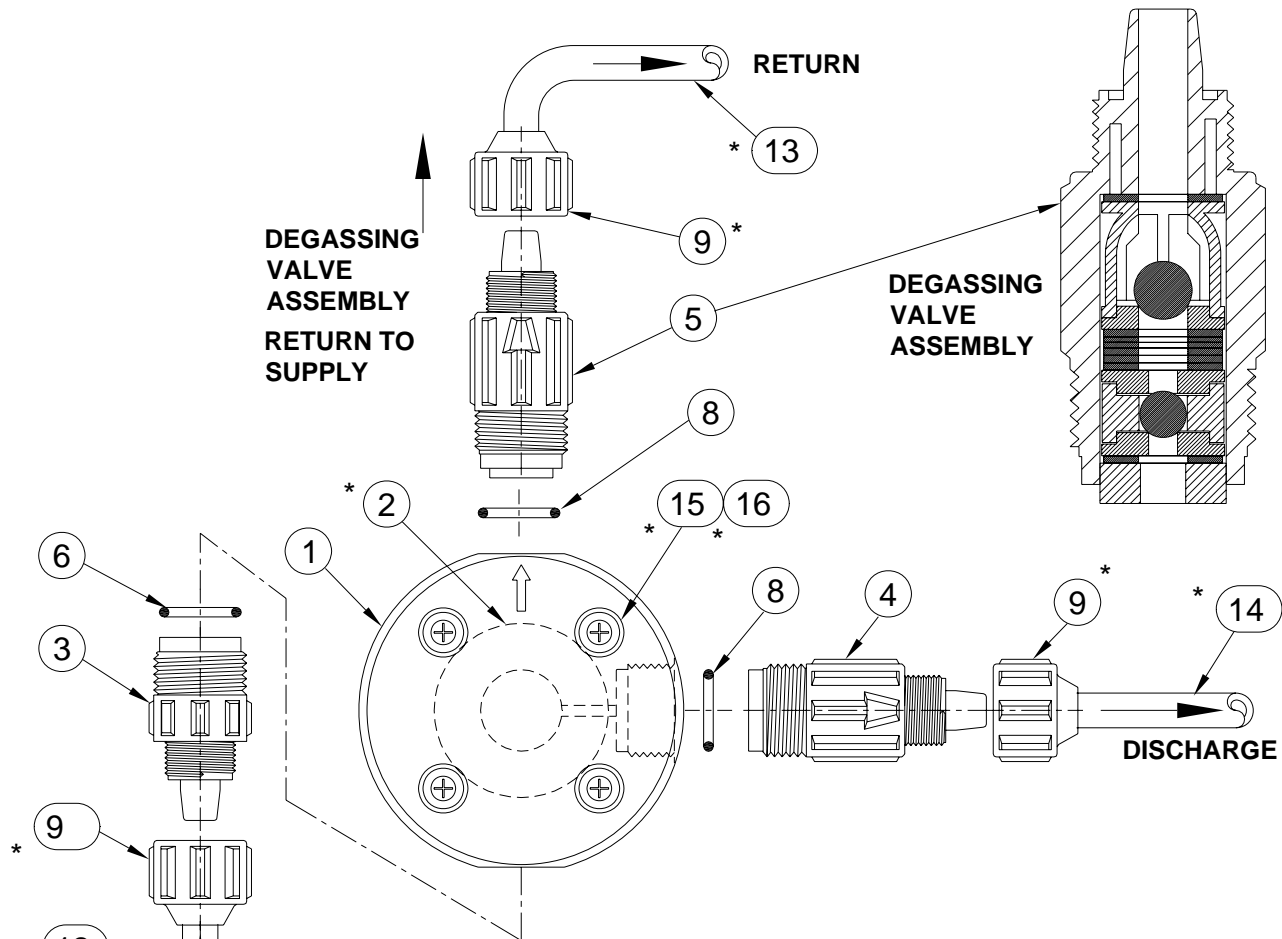

PARTS LIST FOR PUMP MODELS WITH
"VVC9 or "VHC9 IN POSITION 7 thru 10.

ITEM#	PART#	DESCRIPTION	VVC9 VITON			VHC9 HYPALON		
			0.75 QTY	1.0 QTY	1.25 QTY	0.75 QTY	1.0 QTY	1.25 QTY
ASSY.	L0203102-PVC	HEAD ASSY., Ø.75" DEGASS(PVC/VTN)	REF	-	-	-	-	-
	L0203202-PVC	HEAD ASSY., Ø1.00" DEGASS(PVC/VTN)	-	REF	-	-	-	-
	L0203302-PVC	HEAD ASSY., Ø1.25" DEGASS(PVC/VTN)	-	-	REF	-	-	-
ASSY.	L0203112-PVC	HEAD ASSY., Ø.75" DEGASS(PVC/HYP)	-	-	-	REF	-	-
	L0203212-PVC	HEAD ASSY., Ø1.00" DEGASS(PVC/HYP)	-	-	-	-	REF	-
	L0203312-PVC	HEAD ASSY., Ø1.25" DEGASS(PVC/HYP)	-	-	-	-	-	REF
1	L0203900-HPV	PUMP HEAD Ø.75" (HPV)	1	-	-	1	-	-
	L0204000-HPV	PUMP HEAD Ø1.00" (HPV)	-	1	-	-	1	-
	L0204100-HPV	PUMP HEAD Ø1.25" (HPV)	-	-	1	-	-	1
*2	L0300900-THY	DIAPHRAGM Ø.75" (NOT SUPPLIED)	REF	-	-	REF	-	-
	L0301000-THY	DIAPHRAGM Ø1.00" (NOT SUPPLIED)	-	REF	-	-	REF	-
	L0301100-THY	DIAPHRAGM Ø1.25" (NOT SUPPLIED)	-	-	REF	-	-	REF
3	L3100TCJ-PVC	SUCTION VALVE ASSY. (PVC/FTF/CD)	1	-	-	1	-	-
4	L3200VCD-PVC	DISCHARGE VALVE ASSY (PVC/VTN)	1	-	-	-	-	-
	L3200HCD-PVC	DISCHARGE VALVE ASSY (PVC/HYP)	-	-	-	-	1	-
5	L3200DV1-PVC	DEGASS VALVE ASSY (PVC/VTN)	1	-	-	-	-	-
	L3200DH1-PVC	DEGASS VALVE ASSY (PVC/HYP)	-	-	-	-	1	-
6	L1501300-TFE	O-RING, VALVE (TFE)	1	-	-	1	-	-
	L1501300-VTN	O-RING, VALVE (VTN)	2	-	-	-	-	-
8	L1501300-HYP	O-RING, VALVE (HYP)	-	-	-	-	2	-
	*9	L1100300-PVC	COUPLING NUT, .38" - TUBE (PVC)	3	-	-	3	-
*11	24964	COUPLING NUT, .38" - TUBE (PVC)	1	-	-	1	-	
*12	41402	TUBING, Ø.38" X4' SUCTION (PVC)	1	-	-	1	-	
*13	J41424	TUBING, Ø.38" X4' DEGASS RETURN (PE)	1	-	-	1	-	
*14	41403	TUBING, Ø.38" X8' DISCHARGE (PE)	1	-	-	1	-	
*15	L9801700-188	SCREWS, PUMP HEAD (SST)	4	-	-	4	-	
*16	L9801300-188	WASHERS, PUMP HEAD (SST)	4	-	-	4	-	
*17	J60718	STNR ASY,PVD/VTN/C .38T	1	-	-	-	-	
	J60717	STNR ASY,PVD/HYP/C .38T	-	-	-	1	-	
*18	L9906700-000	WEIGHT, CERAMIC TUBE	REF	-	-	REF	-	

* NOT SUPPLIED WITH DEGASSING HEAD ASSEMBLY